

DID 25 standard roller chain

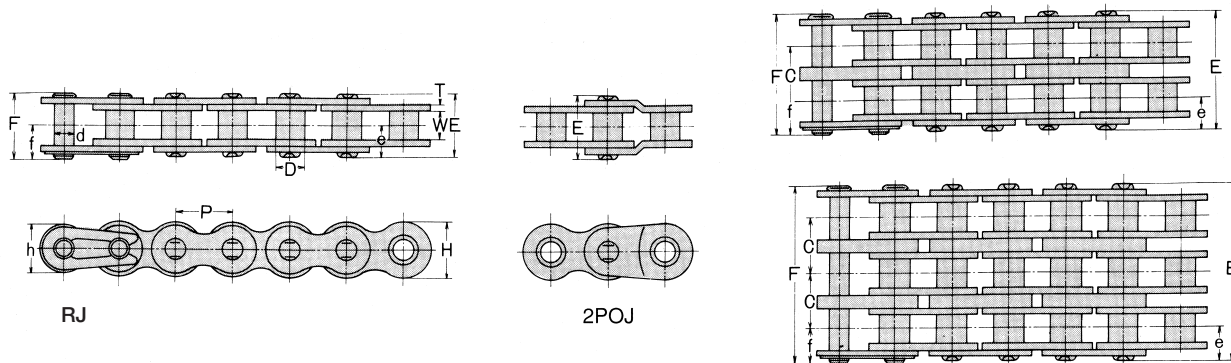

Dimensions

Chain No.		Pitch P	Roller Link Width W	Bush Dia. D	Pin					Transverse Pitch C	Plate				JIS		DID		DID		Approx. Weight (kg/m)	
DID	JIS				d	E	F	e	f		T	H	h	Min. Tensile Strength		Min. Tensile Strength		Avg. Tensile Strength		Max. Allowable Load		
														kN	kgf	kN	kgf	kN	kgf	kN		kgf
DID25	25				7.8	8.5					3.6	367	3.63	370	4.41	450	0.73	75	0.13			
DID25-2	25-2				14.4	15.0					7.2	734	7.26	740	8.82	900	1.17	120	0.26			
DID25-3	25-3	6.35	3.18	3.30	20.8	21.4	3.9	4.7	6.4	0.72	10.8	1,101	10.89	1,110	13.20	1,350	1.76	180	0.39			
DID25-4	25-4				27.2	27.8					14.4	1,468	14.52	1,480	17.60	1,800	2.35	240	0.52			
DID25-5	25-5				33.7	34.3					18.0	1,835	18.15	1,850	20.00	2,250	2.84	290	0.65			

Note: Values of average tensile strength and max. allowable load are for chain body.

Max. Kilowatt Ratings

No. of Teeth of Small Sprocket	Type of Lubrication	Small Sprocket revolutions per minute (rpm) (See P132 for the details of type of lubrication A, B and C.)																																																																																																			
		100					500					900					1200					1800					2500					3000					3500					4000					4500					5000					5500					6000					6500					7000					7500					8000					8500					9000					10000				
		A										B										C																																																																															
11		0.04	0.18	0.31	0.40	0.58	0.77	0.91	1.05	1.03	0.86	0.74	0.64	0.56	0.50	0.44	0.40	0.36	0.33	0.30	0.26																																																																																
12		0.05	0.20	0.34	0.44	0.63	0.85	1.00	1.15	1.17	0.98	0.84	0.73	0.64	0.57	0.51	0.46	0.41	0.38	0.35	0.30																																																																																
13		0.05	0.22	0.37	0.48	0.69	0.93	1.09	1.25	1.32	1.11	0.95	0.82	0.72	0.64	0.57	0.51	0.47	0.43	0.39	0.33																																																																																
14		0.06	0.24	0.40	0.52	0.75	1.00	1.18	1.36	1.48	1.24	1.06	0.92	0.80	0.71	0.64	0.58	0.52	0.48	0.44	0.37																																																																																
15		0.06	0.25	0.43	0.56	0.80	1.08	1.27	1.46	1.64	1.37	1.17	1.02	0.89	0.79	0.71	0.64	0.58	0.53	0.49	0.41																																																																																
16		0.06	0.27	0.46	0.60	0.86	1.16	1.37	1.57	1.77	1.51	1.29	1.12	0.98	0.87	0.78	0.70	0.64	0.58	0.53	0.46																																																																																
17		0.07	0.29	0.49	0.64	0.92	1.24	1.46	1.67	1.89	1.66	1.41	1.23	1.08	0.95	0.85	0.77	0.70	0.64	0.59	0.50																																																																																
18		0.07	0.31	0.52	0.68	0.98	1.32	1.55	1.78	2.01	1.81	1.54	1.34	1.17	1.04	0.93	0.84	0.76	0.70	0.64	0.54																																																																																
19		0.08	0.33	0.56	0.72	1.04	1.40	1.64	1.89	2.13	1.96	1.67	1.45	1.27	1.13	1.01	0.91	0.83	0.75	0.69	0.59																																																																																
20		0.08	0.35	0.59	0.76	1.10	1.47	1.74	2.00	2.25	2.11	1.81	1.56	1.37	1.22	1.09	0.98	0.89	0.81	0.75	0.64																																																																																
21		0.09	0.37	0.62	0.80	1.16	1.55	1.83	2.10	2.37	2.27	1.94	1.68	1.48	1.31	1.17	1.06	0.96	0.88	0.80	0.69																																																																																
22		0.09	0.38	0.65	0.84	1.22	1.63	1.93	2.21	2.50	2.44	2.08	1.81	1.58	1.40	1.26	1.13	1.03	0.94	0.86	0.74																																																																																
23		0.09	0.40	0.68	0.89	1.28	1.71	2.02	2.32	2.62	2.61	2.23	1.93	1.69	1.50	1.34	1.21	1.10	1.00	0.92	0.79																																																																																
24		0.10	0.42	0.72	0.93	1.34	1.80	2.12	2.43	2.74	2.78	2.37	2.06	1.81	1.60	1.43	1.29	1.17	1.07	0.98	0.84																																																																																
25		0.10	0.44	0.75	0.97	1.40	1.88	2.21	2.54	2.86	2.95	2.52	2.19	1.92	1.70	1.52	1.37	1.25	1.14	1.04	0.89																																																																																
28		0.12	0.50	0.85	1.10	1.58	2.12	2.50	2.87	3.24	3.50	2.99	2.59	2.27	2.02	1.81	1.63	1.48	1.35	1.24	1.06																																																																																
30		0.13	0.54	0.91	1.18	1.70	2.28	2.69	3.09	3.49	3.88	3.32	2.87	2.52	2.24	2.00	1.81	1.64	1.50	1.37	1.17																																																																																
32		0.14	0.58	0.98	1.27	1.82	2.45	2.89	3.32	3.74	4.16	3.65	3.17	2.78	2.46	2.21	1.99	1.81	1.65	1.51	1.29																																																																																
35		0.15	0.63	1.08	1.39	2.01	2.70	3.18	3.65	4.12	4.58	4.18	3.62	3.18	2.82	2.52	2.27	2.06	1.89	1.73	1.48																																																																																
40		0.17	0.73	1.24	1.61	2.32	3.12	3.67	4.22	4.76	5.29	5.11	4.43	3.88	3.44	3.08	2.78	2.52	2.30	2.11	1.81																																																																																
45		0.20	0.83	1.41	1.83	2.63	3.54	4.17	4.79	5.40	6.01	6.09	5.28	4.63	4.11	3.68	3.32	3.01	2.75	2.52	2.15																																																																																

Note: Values in the table above are for single strand chains only. For multiplex chains, please apply the coefficient of multi-strand. (See "Chain Selection" on P120).