

BS Roller Chain (British Standard Roller Chain)

DID BS Roller Chains conform to the ISO (International Organization for Standardization) "B series", and they are manufactured in conformity with the British Standard or German Standard. For sprockets, use those in conformity with the BS standard.

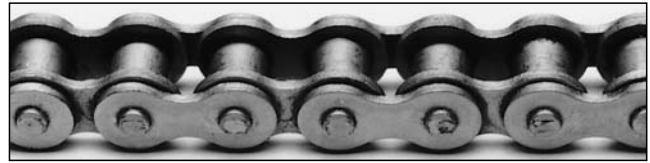

Dimensional drawing

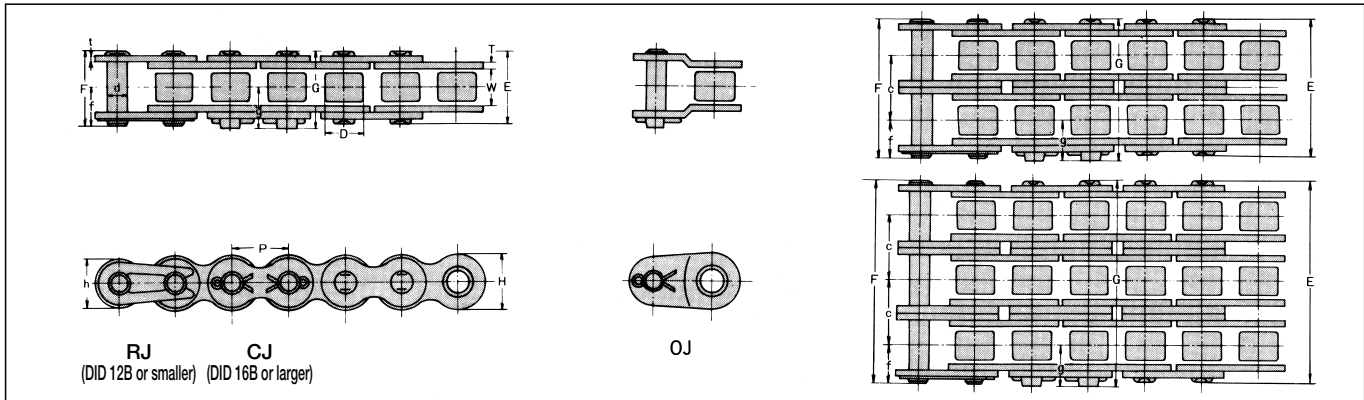

Dimensions

Chain No.		Pitch P	Roller link width W	Roller dia. D	Pin						Transverse pitch C	Plate				JIS Avg. tensile strength		DID Min. tensile strength		Approx. weight (kg/m)
DID	JIS B系				d	E	F	G	f	g		T	t	H	h	kN	kgf	kN	kgf	
DID 04B	—	6.00	2.80	4.00	1.85	6.45	7.35	—	4.15	—	—	0.63	0.63	4.9	4.9	—	—	3.33	340	0.12
DID 05B	05B	—	—	—	—	7.60	8.60	—	—	—	—	—	—	—	—	4.4	449	5.68	580	0.18
DID 05B-2	05B-2	8.00	3.00	5.00	2.31	13.25	14.25	—	4.80	—	5.64	0.75	0.75	7.1	6.2	7.8	795	9.21	940	0.34
DID 06B	06B	—	—	—	—	13.15	13.6	—	—	—	—	—	—	—	—	8.9	908	10.4	1,070	0.39
DID 06B-2	06B-2	9.525	5.72	6.35	3.28	22.75	23.9	—	7.4	—	10.24	1.3	1.0	8.2	8.2	16.9	1,720	19.4	1,980	0.74
DID 06B-3	06B-3	—	—	—	—	33.0	34.3	—	—	—	—	—	—	—	—	24.9	2,539	27.4	2,800	1.10
DID 08B	08B	—	—	—	—	16.7	18.1	—	—	—	—	—	—	—	—	17.8	1,815	19.6	2,000	0.67
DID 08B-2	08B-2	12.70	7.75	8.51	4.45	30.7	32.0	—	9.9	—	13.92	1.5	1.5	11.9	10.4	31.1	3,170	34.3	3,500	1.30
DID 08B-3	08B-3	—	—	—	—	44.6	46.0	—	—	—	—	—	—	—	—	44.5	4,537	49.0	5,000	1.92
DID 10B	10B	—	—	—	—	18.9	20.4	—	—	—	—	—	—	—	—	22.2	2,260	25.4	2,600	0.86
DID 10B-2	10B-2	15.875	9.65	10.16	5.08	35.5	37.0	—	10.9	—	16.59	1.5	1.5	14.7	13.0	44.5	4,537	50.9	5,200	1.68
DID 10B-3	10B-3	—	—	—	—	52.2	53.7	—	—	—	—	—	—	—	—	66.7	6,800	76.4	7,800	2.54
DID 12B	12B	—	—	—	—	22.2	23.6	—	—	—	—	—	—	—	—	28.9	2,946	31.3	3,200	1.14
DID 12B-2	12B-2	19.05	11.68	12.07	5.72	41.7	43.1	—	12.7	—	19.46	1.8	1.8	16.1	14.6	57.8	5,890	62.7	6,400	2.28
DID 12B-3	12B-3	—	—	—	—	61.3	62.7	—	—	—	—	—	—	—	—	86.7	8,840	94.1	9,600	3.46
DID 16B	16B	—	—	—	—	35.1	—	38.2	—	—	—	—	—	—	—	60	6,118	63.7	6,500	2.56
DID 16B-2	16B-2	25.40	17.02	15.88	8.28	67.1	—	70.3	—	20.7	31.88	4.0	3.2	21.0	21.0	106	10,808	127	13,000	5.12
DID 16B-3	16B-3	—	—	—	—	99.1	—	102.2	—	—	—	—	—	—	—	160	16,315	191	19,500	7.59
DID 20B	20B	—	—	—	—	41.0	—	44.0	—	—	—	—	—	—	—	95	9,687	98.0	10,000	3.81
DID 20B-2	20B-2	31.75	19.56	19.05	10.19	77.4	—	80.5	—	23.5	36.45	4.5	3.5	26.4	26.4	170	17,335	196	20,000	7.57
DID 20B-3	20B-3	—	—	—	—	114.0	—	117.0	—	—	—	—	—	—	—	250	25,490	294	30,000	11.3
DID 24B	24B	—	—	—	—	53.4	—	58.7	—	—	—	—	—	—	—	160	16,315	166	17,000	7.08
DID 24B-2	24B-2	38.10	25.40	25.40	14.63	101.8	—	107.1	—	32.0	48.36	6.0	5.0	33.4	33.4	280	28,550	333	34,000	13.9
DID 24B-3	24B-3	—	—	—	—	150.2	—	155.5	—	—	—	—	—	—	—	425	43,337	500	51,000	20.7

- Note: 1. 2POJ offset links are used for DID04B and DID05B.
- 2. DID06B has flat oval-shaped plates.
- 3. Clip connecting links (RJ) are used for DID06B-12B and cotter connecting links (CJ) for DID16B-24B.