

## Roller Chain Coupling

### Features

#### 1. Simple structure

A roller chain coupling consists of one duplex roller chain and two sprockets for a simplex chain. Handling is very simple as both the shafts (driving shaft and driven shaft) can be connected and disconnected by inserting or removing connecting pins (cotter type).

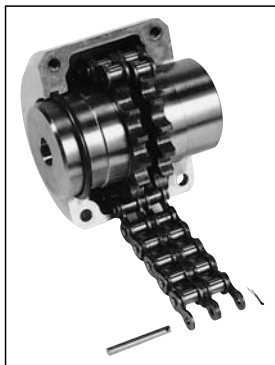

#### 2. Easy alignment

Owing to the play between the respective components of the chain and the play between the roller chain and the sprockets, the eccentricity and angle error can be generally allowed as follows:

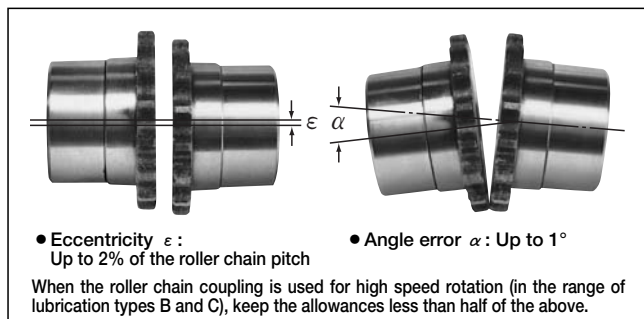

#### 3. Small but powerful

Since a powerful roller chain is engaged with the sprockets at all the teeth, a large torque can be transmitted, though the coupling itself is smaller than other kinds of couplings.

#### 4. Excellent durability

The roller chain is made of heat-treated steel and manufactured precisely and solidly to the highest manufacturing standard. The durability is outstanding and little time is required for maintenance as the sprockets have induction-hardened special teeth, and are always engaged with the roller chain.

#### 5. Protection of machine

Rational flexibility decreases vibration, overheating and wear of the bearings caused by the eccentricities and angle errors of the shafts.

#### Standard housing

The standard housings for No. 8022 or smaller are made of aluminum alloy die casting, and those for No. 10020 or larger are made of aluminum alloy casting. Installation of housings has the following advantages.



### 1. Advantages of housing

- **Holding of lubrication**  
Since a roller chain coupling rotates with flexibility, the teeth of the roller chain and sprockets slide slightly during operation. So, they must be kept lubricated for prevention of wear as much as possible. The housing functions as a grease box for the lubrication.
- **Prevention of grease scattering**  
Especially in high speed rotation, grease may be scattered by centrifugal force. The housing functions as a protector that prevents this.
- **Protection from dust and moisture (corrosive atmosphere)**  
When a roller chain coupling is used in a wear-causing or corrosive circumstances, the chain life is extremely shortened unless the coupling is perfectly shielded from the circumstances. The housing functions to protect the roller chain coupling, preventing the shortening of life.
- **High safety and neat appearance**  
Since the housing has no protrusions outside, it is safe even if it rotates with the roller chain coupling. It is also neat in appearance. (To avoid possible injury, do not touch the housing when rotating.)

### 2. Structure

The roller chain coupling can be split in the direction perpendicular to the shafts. The hole on the driving shaft side of the housing firmly holds the coupling's sprocket hub. The hole on the driven shaft side keeps a clearance of 1 mm or more from the sprocket hub to maintain flexibility of the coupling. Oil leakage from this portion is prevented by a seal ring.

### Cautions

- |   |  |
|---|--|
| For safe work   | <ul style="list-style-type: none"> <li>● Always wear clothing suitable for work and proper protection (safety glasses, safety shoes, etc.).</li> <li>● Strictly observe Section 1 "General standards (prevention of danger by motors, revolving shafts, etc.), Chapter 1, Part 2 of Occupational Safety and Health Regulations.</li> <li>● Be sure to switch off the electric power source or any other power source before starting maintenance work, and ensure that the power is never accidentally switched on. Furthermore, make sure not to allow your clothes or any parts of the body to be caught by the chain or sprockets, or by any other nearby equipment.</li> </ul> |
| Housings and safety covers                                  | <ul style="list-style-type: none"> <li>● Be sure to install a chain housing for type C and type B (see "Table of Lubrication Types").</li> <li>● For installing the roller chain coupling into a high-speed machine or heavily vibrating machine, coat the bolts with a loosening preventive.</li> <li>● Install a safety cover to prevent any unexpected flying of loosened bolts, or scattering of a broken housing or chain.</li> </ul>   |
| Inhibition of modification, re-use, and partial replacement | <ul style="list-style-type: none"> <li>● Never partially replace or re-use the coupling as its strength will be lowered, causing damage or destruction. Furthermore, since the coupling is heat-treated, never modify the cotter holes or any other parts. When replacement is necessary, replace the roller chain coupling or housing as a set respectively.</li> </ul>   |
| Noise   | <ul style="list-style-type: none"> <li>● Noise during operation may be caused by malfunction and the unit may need to be replaced. Immediately switch off the power, and check the cause.</li> </ul>   |

## Lubrication of roller chain coupling

The lubrication of a roller chain coupling belongs to the following three types: A, B and C, depending on the speed of rotation used. Refer to the table of Max. Horsepower Ratings (P112).

### 1. Lubrication types

Type A	Greasing once a month.
Type B	Greasing every 1 ~ 2 weeks, or install a lubrication housing.
Type C	Be sure to install a housing, and replace grease every 3 months.

### 2. Grease

Since a roller chain coupling is usually used at high speed for a long time, grease must satisfy the following conditions.

- Excellent in mechanical stability, oxidation stability and adhesion.
- Grease based on metallic soap: For low speed

operation, grease based on sodium soap, i.e., fiber grease can be used, but for high speed operation (for lubrication type B and C), be sure to use grease based on lithium soap.

### 3. Greasing amount

Fill appropriate amount of grease in the housing in accordance with the following table.

Roller chain coupling No.	Required amount of grease kg	Roller chain coupling No.	Required amount of grease kg
<b>DID C-4012</b>	0.10	<b>DID C-10020</b>	1.8
<b>DID C-4014</b>	0.13	<b>DID C-12018</b>	3.2
<b>DID C-4016</b>	0.17	<b>DID C-12022</b>	4.4
<b>DID C-5014</b>	0.22	<b>DID C-16018</b>	7.2
<b>DID C-5016</b>	0.26	<b>DID C-16022</b>	9.9
<b>DID C-5018</b>	0.36	<b>DID C-20018</b>	11.8
<b>DID C-6018</b>	0.5	<b>DID C-20022</b>	15.8
<b>DID C-6022</b>	0.7	<b>DID C-24022</b>	21.9
<b>DID C-8018</b>	0.9	<b>DID C-24026</b>	28.1
<b>DID C-8022</b>	1.2		

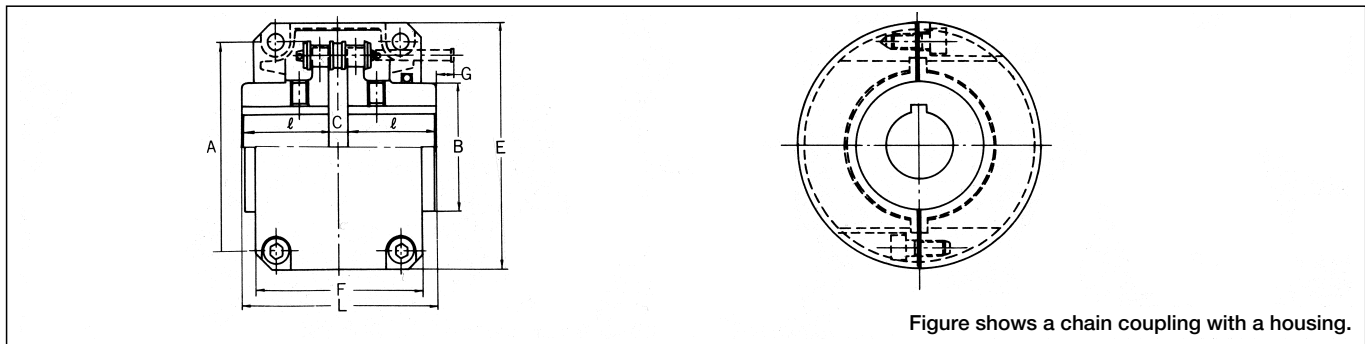

Figure shows a chain coupling with a housing.

## Dimensions

Roller chain coupling No.		Applicable range of shaft dia.	Prepared hole dia.	E	F	A (max.)	L	l	C	B	G	Set screw	Max. allowable torque of under 50rpm		Allowable rotation (r/min)	Approx. weight (kg)	Moment of inertia $\times 10^{-3}$ kg·m	GD <sup>2</sup> $\times 10^{-3}$ kgf·m <sup>2</sup>
DID	JIS												kN·m	kgf·m				
<b>DID C-4012</b>	4012	11~22	10	75	75	61	79.4	36	7.4	35	9	M 6	0.249	25.4	4,800	1.1	0.55	2.20
<b>DID C-4014</b>	4014	14~28	10	84	75	69	79.4	36	7.4	43	9	M 6	0.329	33.6	4,800	1.3	0.97	3.85
<b>DID C-4016</b>	4016	16~32	14	92	75	77	87.4	40	7.4	50	6	M 6	0.419	42.8	4,800	1.85	1.44	5.76
<b>DID C-5014</b>	5014	16~35	14	102	85	86	99.7	45	9.7	53	11	M 8	0.620	63.3	3,600	2.7	2.80	11.2
<b>DID C-5016</b>	5016	18~40	14	111	85	96	99.7	45	9.7	60	11	M 8	0.791	80.7	3,600	3.25	3.70	14.8
<b>DID C-5018</b>	5018	18~45	14	122	85	106	99.7	45	9.7	70	11	M 8	0.979	99.9	3,000	4.25	5.63	22.5
<b>DID C-6018</b>	6018	22~56	18	142	106	128	123.5	56	11.5	85	15	M10	1.81	185	2,500	7.3	13.73	54.9
<b>DID C-6022</b>	6022	28~75	18	167	106	152	123.5	56	11.5	110	15	M10	2.61	267	2,500	11.6	29.5	118
<b>DID C-8018</b>	8018	32~80	23	186	130	170	141.2	63	15.2	115	27	M12	3.92	400	2,000	16.15	52.0	208
<b>DID C-8022</b>	8022	40~100	28	220	130	203	157.2	71	15.2	140	19	M12	5.64	576	1,800	24.3	111	444
<b>DID C-10020</b>	10020	45~110	40	255	160	233	178.8	80	18.8	160	29	M12	8.40	857	1,800	39.7	244	976
<b>DID C-12018</b>	12018	50~125	45	280	184	255	202.7	90	22.7	170	47	M12	12.7	1,300	1,500	53.8	394	1,575
<b>DID C-12022</b>	12022	56~140	50	330	190	303	222.7	100	22.7	200	37	M12	18.3	1,870	1,250	77.1	781	3,122
<b>DID C-16018</b>	16018	63~160	55	375	240	340	254.1	112	30.1	225	64	M16	26.4	2,700	1,100	108	1,453	5,811
<b>DID C-16022</b>	16022	80~200	70	440	245	405	310.1	140	30.1	280	36	M16	38.1	3,890	1,000	187	3,222	12,890
<b>DID C-20018</b>	—	82~205	75	465	285	425	437.5	200	37.5	290	15	M20	54.1	5,520	800	286	5,098	20,390
<b>DID C-20022</b>	—	100~255	90	545	300	506	477.5	220	37.5	360	—	M20	77.8	7,940	600	440	11,110	44,450
<b>DID C-24022</b>	—	120~310	110	650	340	607	650	302.5	45.0	445	—	M20	137	14,000	600	869	31,000	124,100
<b>DID C-24026</b>	—	150~360	140	745	350	704	700	327.5	45.0	525	—	M20	186	19,000	500	1,260	59,850	239,400

Note: 1. Dimension G indicates the required margin for assembling and disassembling of the roller chain coupling.

2. Allowable rotation is applicable only when the housing is mounted.

3. The weight of the housing and grease is included in Approx. weight and GD<sup>2</sup>.

## Selection of roller chain coupling

### 1. Selection by drive performance

- Based on the type of motor, operation time per day, and the type of load, obtain the service factor in the table of service factors.
- Multiply the power (kW) to be transmitted, by the service factor identified in the following table, to obtain a corrected power to be transmitted (kW).  

$$\text{Transmission power (kW)} \times (\text{Service factor}) = \text{Corrected transmission power (kW)}$$

**Table of Service Factor**

Type of load	Operating time/day	Source of power		
		Electric motor or turbine	Steam engine/gasoline engine (with 4 cylinders or more)	Diesel engine/gas engine
Load variation, impact, start torque is small (No reverse)	8 hrs or less	1.0	1.5	2.0
	8-16 hrs	1.5	2.0	2.5
	16 hrs or more	2.0	2.5	3.0
Load variation, impact is at medium level (No reverse)	8 hrs or less	1.5	2.0	2.5
	8-16 hrs	2.0	2.5	3.0
	16 hrs or more	2.5	3.0	3.5
Load variation, impact, start torque is large, (No reverse)	8 hrs or less	2.0	2.5	3.0
	8-16 hrs	2.5	3.0	3.5
	16 hrs or more	3.0	3.5	4.0

Note: Service factor of 8 hours or less to be applied regardless of operation time when the revolution is under 50 r/min.

- Select a roller chain coupling in the drive performance (kW ratings) table: Identify the chain coupling number when the transmission power starts to exceed the corrected transmission power (calculated in 2.) according to the motor rpm.
- When the shaft diameter is within the range of the selected roller chain coupling shaft diameter, select the coupling. When the shaft diameter exceeds the maximum shaft diameter of the roller chain coupling, select a one size larger coupling.

A table of ANSI key slot dimensions is shown on the following page.

### 2. Selection when connected with an electric motor directly

Low voltage three-phase squirrel-cage induction motor (ANSI standard)			Roller chain coupling No.
Output (kW)		Shaft dia. (mm)	
4 poles	6 poles	E type	
0.4	—	14	<b>DID C-4012</b>
0.75	0.4	19	
1.5	0.75	24	<b>DID C-4016</b>
2.2	1.5	28	
3.7	2.2	28	
5.5	3.7	38	<b>DID C-5016</b>
7.5	5.5	38	
11	7.5	42	<b>DID C-5018</b>
—	11	42	

Note: 1. Drive performance selecting method to be applied when the output of motor exceeds 15 kW.

2. Table of dimensions of roller chain coupling is applied when the shaft diameter of motor is not given in the table above.

## Drive performance (kW ratings)

Roller chain coupling No.	Max. allowable torque under 50 r/min		Number of revolution (r/min)																				Unit (kW)					
	kN·m	kgf·m	1	5	10	25	50	100	200	300	400	500	600	800	1000	1200	1500	1800	2000	2500	3000	3600		4000	4800	5200	6000	
<b>DID C-4012</b>	0.249	25.4	0.03	0.13	0.26	0.65	1.31	2.00	3.11	4.06	4.91	5.72	6.48	7.94	9.33	10.6	12.6	14.5	15.7	18.9	21.9	25.6	28.1	33.0				
<b>DID C-4014</b>	0.329	33.6	0.03	0.17	0.35	0.86	1.73	2.65	4.12	5.37	6.50	7.56	8.58	10.5	12.3	14.1	16.7	19.2	20.8	25.0	29.0	33.9	37.1	43.6				
<b>DID C-4016</b>	0.419	42.8	0.04	0.22	0.44	1.10	2.20	3.38	5.25	6.84	8.28	9.64	10.9	13.3	15.7	17.9	21.2	24.5	26.6	31.8	37.0	43.2	47.3	55.6				
<b>DID C-5014</b>	0.620	63.3	0.07	0.33	0.65	1.63	3.25	4.99	7.75	10.1	12.2	14.2	16.1	19.7	23.2	26.5	31.4	36.1	39.3	47.0	54.7	63.8						
<b>DID C-5016</b>	0.791	80.7	0.08	0.41	0.83	2.07	4.14	6.35	9.88	12.8	15.5	18.1	20.5	25.1	29.5	33.8	40.0	46.1	50.0	59.9	69.7	81.3						
<b>DID C-5018</b>	0.979	99.9	0.10	0.51	1.03	2.57	5.13	7.87	12.2	15.9	19.3	22.4	25.4	31.1	36.6	41.8	49.5	57.0	62.0	74.2	86.3							
<b>DID C-6018</b>	1.81	185	0.19	0.95	1.91	4.77	9.54	14.6	22.7	29.6	35.8	41.7	47.3	57.9	68.1	77.8	92.1	106	115	138								
<b>DID C-6022</b>	2.61	267	0.27	1.37	2.74	6.86	13.7	21.0	32.7	42.6	51.6	60.0	68.1	83.4	97.9	112	132	152	165	198								
<b>DID C-8018</b>	3.92	400	0.41	2.06	4.11	10.2	20.6	31.5	49.0	63.8	77.3	89.9	102	124	146	167	198	228	248									
<b>DID C-8022</b>	5.64	576	0.59	2.96	5.91	14.8	29.6	45.3	70.4	91.8	111	129	146	179	211	241	285	329	357									
<b>DID C-10020</b>	8.40	857	0.88	4.40	8.80	22.0	44.0	67.4	104	136	165	192	218	267	314	359	425	489										
<b>DID C-12018</b>	12.7	1,300	1.33	6.67	13.3	33.4	66.7	102	159	207	251	292	331	405	476	544	644											
<b>DID C-12022</b>	18.3	1,870	1.92	9.60	19.2	48.0	96.0	147	228	298	361	420	476	583	685	783												
<b>DID C-16018</b>	26.4	2,700	2.78	13.9	27.8	69.5	139	213	331	431	523	608	690	845	992													
<b>DID C-16022</b>	38.1	3,890	4.00	20.0	40.0	100	200	306	476	621	752	875	992	1210	1420													
<b>DID C-20018</b>	54.1	5,520	5.67	28.3	56.7	142	283	434	675	880	1060	1240	1400	1720														
<b>DID C-20022</b>	77.8	7,940	8.15	40.8	81.5	204	408	625	971	1260	1530	1780	2020															
<b>DID C-24022</b>	137	14,000	14.4	72.2	144	361	722	1100	1720	2240	2710	3160	3580															
<b>DID C-24026</b>	186	19,000	19.5	97.7	195	489	977	1490	2320	3030	3670	4270																
Type of lubrication	A		B					C																				

Note: Please refer to P133 for type of lubrication

### 3. Dimensions of ANSI key slot

#### New ANSI key slot (ANSI 1301-1976)

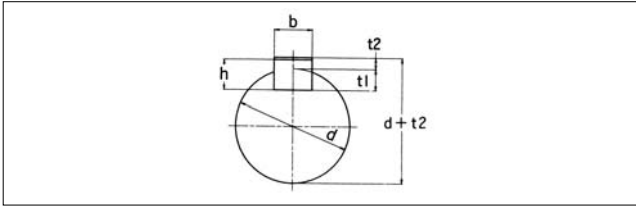

Shaft dia. <b>d</b>	Dimension of key 幅×高 <b>b×h</b>	Depth of key slot			
		Shaft <b>t1</b>	Hub <b>d+t2</b>		
			Parallel key	Sloped key	
Over 6 8 or less	2×2	1.2	d+ 1.0	d+ 0.5	
8 ∕ 10 ∕	3×3	1.8	d+ 1.4	d+ 0.9	
10 ∕ 12 ∕	4×4	2.5	d+ 1.8	d+ 1.2	
12 ∕ 17 ∕	5×5	3.0	d+ 2.3	d+ 1.7	
17 ∕ 22 ∕	6×6	3.5	d+ 2.8	d+ 2.2	
20 ∕ 25 ∕	(7×7)	4.0	d+ 3.0	d+ 3.0	
22 ∕ 30 ∕	8×7	4.0	d+ 3.3	d+ 2.4	
30 ∕ 38 ∕	10× 8	5.0	d+ 3.3	d+ 2.4	
38 ∕ 44 ∕	12× 8	5.0	d+ 3.3	d+ 2.4	
44 ∕ 50 ∕	14× 9	5.5	d+ 3.8	d+ 2.9	
50 ∕ 55 ∕	(15×10)	5.0	d+ 5.0	d+ 5.0	
50 ∕ 58 ∕	16×10	6.0	d+ 4.3	d+ 3.4	
58 ∕ 65 ∕	18×11	7.0	d+ 4.4	d+ 3.4	
65 ∕ 75 ∕	20×12	7.5	d+ 4.9	d+ 3.9	
75 ∕ 85 ∕	22×14	9.0	d+ 5.4	d+ 4.4	
80 ∕ 90 ∕	(24×16)	8.0	d+ 8.0	d+ 8.0	
85 ∕ 95 ∕	25×14	9.0	d+ 5.4	d+ 4.4	
95 ∕ 110 ∕	28×16	10.0	d+ 6.4	d+ 5.4	
110 ∕ 130 ∕	32×18	11.0	d+ 7.4	d+ 6.4	
125 ∕ 140 ∕	(35×22)	11.0	d+11.0	d+11.0	
130 ∕ 150 ∕	36×20	12.0	d+ 8.4	d+ 7.1	
140 ∕ 160 ∕	(38×24)	12.0	d+12.0	d+12.0	
150 ∕ 170 ∕	40×22	13.0	d+ 9.4	d+ 8.1	
160 ∕ 180 ∕	(42×26)	13.0	d+13.0	d+13.0	
170 ∕ 200 ∕	45×25	15.0	d+10.4	d+ 9.1	
200 ∕ 230 ∕	50×28	17.0	d+11.4	d+10.1	

#### ANSI parallel, sloped key slot (ANSI B 1301-1959)

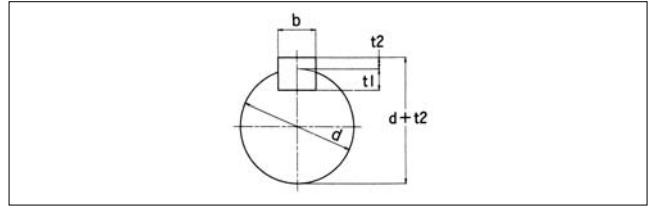

Shaft dia. <b>d</b>	Dimension of key 幅×高 <b>b×h (t2+t1)</b>	Depth of key slot	
		Shaft <b>t1</b>	Hub <b>d+t2</b>
		10 or more 13 or less	4× 4
Over 13 20 ∕	5× 5	3.0	d+ 2.0
20 ∕ 30 ∕	7× 7	4.0	d+ 3.0
30 ∕ 40 ∕	10× 8	4.5	d+ 3.5
40 ∕ 50 ∕	12× 8	4.5	d+ 3.5
50 ∕ 60 ∕	15×10	5	d+ 5
60 ∕ 70 ∕	18×12	6	d+ 6
70 ∕ 80 ∕	20×13	7	d+ 6
80 ∕ 95 ∕	24×16	8	d+ 8
95 ∕ 110 ∕	28×18	9	d+ 9
110 ∕ 125 ∕	32×20	10	d+10
125 ∕ 140 ∕	35×22	11	d+11
140 ∕ 160 ∕	38×24	12	d+12
160 ∕ 180 ∕	42×26	13	d+13
180 ∕ 200 ∕	45×28	14	d+14
200 ∕ 224 ∕	50×31.5	16	d+15.5
224 ∕ 250 ∕	56×35.5	18	d+17.5

## DID C-Top (Chain Cover)

**PAT.**

DID C-Top is a plastic cover for chains that can be easily attached. It has sufficient load strength for chains conveying goods. Unlike conventional plastic chains, it can be used under high tension as stainless steel chains. It is an ideal solution for the use that requires the strength of steel chains free from concerns of damaging, soiling, and jamming of products. It also prevents operators from being caught by the chains. It can also be used as the cover for chains used for elevating devices such as multilevel parking machines.

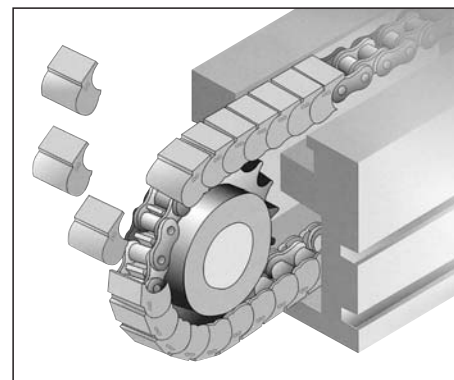

Note: Stock product

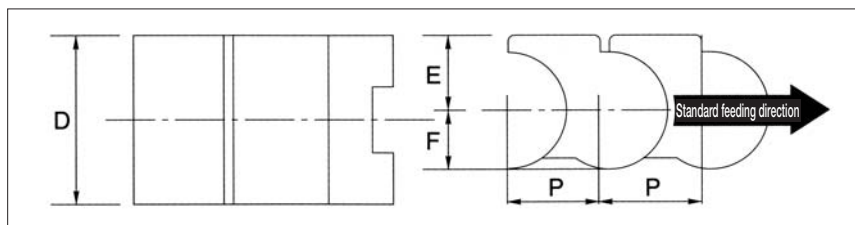

### Applicable chains

Can be attached to chains corresponding to ANSI #40, 50, 60.

### Sprocket teeth number

Use sprockets with 12 or more teeth.  
※Check the outer diameter of the hub.

### Color

The standard color for this product is blue gray. Other colors can be provided depending on the quantity. Consult us.

### Dimensions

Unit (mm)

Cover No.	Dimension (mm)				Weight (g/link) ※A, B
	P	D	E	F	
<b>DID CT-40</b>	12.70	27	10	7.6	4.5
<b>DID CT-50</b>	15.88	32	12	9.5	7.6
<b>DID CT-60</b>	19.05	37	14	11.2	11.5

●Material: POM ●200/package

### Live load

<b>DID CT-40</b>	6kg/pitch
<b>DID CT-50</b>	8kg/pitch
<b>DID CT-60</b>	10kg/pitch

## DID Chain Lube (420 ml)/ DID HI-PWR Lube (330 ml)

Chain Lube is a spray type lubricant that was developed specifically for chains. It has outstanding features that lengthens the chain life preventing it from wearing and maximizes the chain's transmission efficiency.

### Applications

- Roller Chains for Power Transmissions
- O-ring chains
- Leaf chains
- General conveyor chains
- Motorcycle chains
- Bicycle chains
- Sprockets

### Features

- Good adhesion and less splatter.
- Good lubricity to enhance wear resistance.
- Good penetration.
- High corrosion prevention effect.
- Good water resistance and unlikely to be washed away by water.
- Excellent heat resistance.
- Does not impair the O-rings.

- Set number: Chain Lubes: 24/case, HI-PWR Lubes: 48/case
- Stock product



Chain lube  
(Mainly for drive use)



HI-PWR lube  
(Mainly for conveyor use)

## Chain Wear-elongation Check Gage

This gage checks the wear-elongation of chains.

- Check the chain elongation at a portion which is most frequently engaged with the sprockets (portion most likely to be worn).
  - When the center of the pin of the chain to be measured reaches the arrow point, it means that the chain has been critically elongated. In this case, replace the chain.
- ※Use the gage to check the wear elongation of your chain.



Note: Stock product