

Leaf Chain

Leaf chains consist of pins and plates only and are higher in strength than roller chains. They are suitable for tasks like hoisting and pulling. Leaf chains conform to ANSI and have two types: AL and BL.

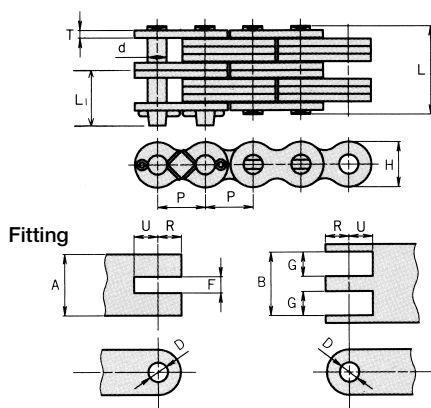



Dimensions

Unit (mm)

Chain No.	Pitch P	Plate		Pin		Min. tensile strength		Max. allowable load		Approx. weight (kg/m)	Fitting							
		H (Max)	T	d	L (Max)	L1 (Max)	kN	kgf	kN		kgf	b (Min)	R	U (Min)	F (Min)	G (Min)	A (Max)	B (Min)
DID AL 422	12.59	10.4	1.5	3.97	8.1	6.0	16.6	1,700	1.86	190	0.40	4.00	6.3	6.3	—	—	3.0	3.3
DID AL 444					14.6	9.8	33.3	3,400	3.43	350	0.77				3.3	3.3	9.3	9.7
DID AL 466					21.1	12.6	50.0	5,100	3.92	400	1.14				3.3	3.3	15.7	16.1
DID AL 522	15.75	13.0	2.0	5.09	10.5	7.3	27.9	2,850	3.04	310	0.65	5.12	7.9	7.9	—	—	4.0	4.3
DID AL 544					19.0	11.5	55.8	5,700	5.29	540	1.26				4.3	4.3	12.3	12.7
DID AL 566					27.5	15.8	83.8	8,550	6.27	640	1.85				4.3	4.3	20.7	21.1
DID AL 622	19.05	15.6	2.4	5.96	12.5	8.8	38.2	3,900	4.41	450	0.90	6.00	9.5	9.5	—	—	4.8	5.1
DID AL 644					22.7	13.9	76.4	7,800	7.45	760	1.75				5.1	5.1	14.7	15.1
DID AL 666					32.8	19.0	114	11,700	8.72	890	2.59				5.1	5.1	24.7	25.1
DID AL 822	25.28	20.8	3.2	7.94	16.4	11.0	66.6	6,800	7.35	750	1.55	8.00	12.7	12.7	—	—	6.4	6.8
DID AL 844					29.7	17.8	133	13,600	13.2	1,350	3.04				6.8	6.8	19.8	20.1
DID AL 866					43.1	24.5	200	20,400	15.3	1,570	4.51				6.8	6.8	32.9	33.4
DID AL 1022	31.64	26.0	4.0	9.54	19.1	13.1	100	10,200	11.5	1,180	2.46	9.60	15.8	15.8	—	—	8.0	8.4
DID AL 1044					36.4	21.3	200	20,400	20.5	2,100	4.80				8.4	8.4	24.4	24.9
DID AL 1066					53.1	29.7	423	30,600	24.0	2,450	7.15				8.4	8.4	40.9	41.4
DID AL 1222	37.98	31.2	4.8	11.11	23.8	15.3	141	14,400	16.4	1,680	3.32	11.20	19.0	19.0	—	—	9.6	10.0
DID AL 1244					43.4	25.2	282	28,800	29.1	2,970	6.50				10.0	10.0	29.2	29.7
DID AL 1266					63.4	35.1	423	43,200	34.2	3,490	9.68				10.0	10.0	48.9	49.4
DID AL 1444	44.32	36.3	5.6	12.71	50.6	30.1	372	38,000	38.9	3,970	10.0	12.80	22.2	22.2	11.6	11.6	34.0	34.5
DID AL 1446					73.6	41.6	558	57,000	46.0	4,700	14.6				11.6	11.6	56.9	57.4
DID AL 1644					83.6	46.4	706	72,000	58.8	6,000	19.6				13.2	13.2	38.8	39.4
DID AL 1666	50.62	41.4	6.4	14.29	83.6	46.4	706	72,000	58.8	6,000	19.6	14.40	25.4	25.4	13.2	13.2	64.9	65.5
DID BL 423	12.70	12.0	2.0	5.09	12.5	8.5	24.5	2,500	4.51	460	0.86	5.12	6.3	6.3	—	—	6.0	6.3
DID BL 434					16.9	10.6	37.2	3,800	5.29	540	1.16				4.3	4.3	10.3	10.7
DID BL 446					23.2	13.7	49.0	5,000	5.98	610	1.69				4.3	4.3	16.3	16.8
DID BL 523	15.875	15.0	2.4	5.96	15.0	9.9	39.2	4,000	6.86	700	1.30	6.00	7.9	7.9	—	—	7.2	7.5
DID BL 534					20.2	12.5	58.8	6,000	8.33	850	1.73				2.6	5.1	12.3	12.7
DID BL 546					27.7	16.3	78.4	8,000	9.41	960	2.44				5.1	7.6	19.5	20.0
DID BL 623	19.05	18.1	3.2	7.94	19.8	12.6	68.6	7,000	9.80	1,000	2.08	8.00	9.5	9.5	—	—	9.7	10.0
DID BL 634					26.7	16.2	103	10,500	12.2	1,250	2.85				6.8	6.8	16.2	16.9
DID BL 646					36.7	21.1	127	13,000	13.7	1,400	4.07				6.8	10.1	26.0	26.6
DID BL 823	25.40	24.0	4.0	9.54	24.0	15.3	102	10,500	16.9	1,730	3.25	9.60	12.7	12.7	—	—	12.1	12.4
DID BL 834					32.4	19.3	154	15,800	20.5	2,100	4.50				4.2	8.4	20.2	20.9
DID BL 846					44.8	25.5	205	21,000	23.5	2,400	6.39				8.4	12.5	32.4	33.0
DID BL 1023	31.75	29.9	4.8	11.11	28.6	17.7	141	14,400	25.9	2,650	4.33	11.20	15.8	15.8	—	—	14.4	14.8
DID BL 1034					38.6	22.7	220	22,500	31.3	3,200	6.03				5.0	10.0	24.2	24.9
DID BL 1046					53.9	30.2	282	28,800	36.2	3,700	8.53				10.0	14.9	38.8	39.4
DID BL 1223	38.10	35.9	5.6	12.71	33.3	21.5	193	19,700	36.7	3,750	6.06	12.80	19.0	19.0	—	—	16.8	17.3
DID BL 1234					44.8	27.2	313	32,000	44.1	4,500	8.45				5.9	11.6	28.0	28.8
DID BL 1246					61.7	36.1	386	39,400	50.5	5,150	12.0				11.6	17.4	45.2	45.9
DID BL 1423	44.45	41.9	6.4	14.29	37.6	23.4	254	26,000	49.0	5,000	8.74	14.40	22.2	22.2	—	—	19.2	19.7
DID BL 1434					50.7	30.0	421	43,000	58.8	6,000	10.9				6.7	13.2	32.0	32.8
DID BL 1446					70.4	39.8	509	52,000	67.6	6,900	20.3				13.2	19.8	51.6	52.3
DID BL 1623	50.80	47.8	7.1	17.46	41.7	26.7	353	36,000	58.8	6,000	11.9	17.60	25.4	25.4	—	—	21.3	21.8
DID BL 1634					56.4	34.0	554	56,500	70.6	7,200	16.6				7.4	14.6	35.5	36.3
DID BL 1646					78.0	44.8	706	72,000	80.4	8,200	23.6				14.6	11.9	57.2	57.9

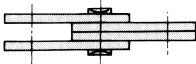
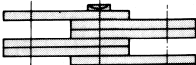
Note: 1. Except for AL-60 series, the pitch of AL type chains is slightly different to that of ANSI standard.
2. The values of max. allowable tension are not applied to connecting links.

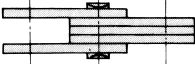
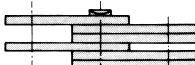
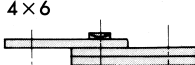
AL type	BL type
For the use that static load is applied with little concern of wearing.	For the use that wear resistance is required since impact load is applied.
<p>2 × 2</p>  <p>4 × 4</p>  <p>6 × 6</p> 	<p>2 × 3</p>  <p>3 × 4</p>  <p>4 × 6</p> 

Selection of leaf chains

The chain size is selected according to the following formula:

$$\text{Acting tension} \times \text{Service factor} \leq \text{Maximum allowable tension}$$

Notes: 1. Acting tension includes the dead weight of the chain, the weight of the attachments and inertia.

2. If the chain speed exceeds 30 m/min, use a DID roller chain.

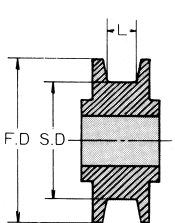

Minimum sheave diameter: $S.D = \text{Chain pitch} \times 5$

Minimum width between flanges: $L = \text{Overall length of pin} \times 1.05$

- If connecting pins are provided: $L \geq 2L_1 \times 1.05$
L₁ is the value stated in the dimensions table.

$F.D = S.D + \text{Maximum link plate height (H)}$

Note: • If dimension H exceeds 25.4, $F.D = S.D + 25.4$ can be adopted as the minimum flange outer diameter.







Service factor

Type of Impact	Service factor	Examples of applications	Applicable chains
Smooth transmission When starts and stops are smooth and loads hardly vary.	1.0	For lifting a balance weight, stretching in cold and hot processing etc.	AL type
With some shock When starts, stops, load variations or reversing occurs often.	1.2	Forklift, etc.	AL type and BL type
With large shock When sudden start, stop or reversing occurs and load largely varies.	1.4	Mining and construction machinery, etc.	BL type and DID roller chains

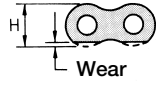
Periodical inspection and instructions for replacement

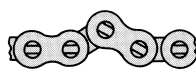
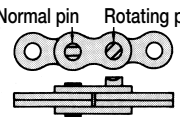
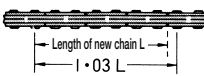
Be sure to carry out periodical inspection and lubrication to confirm safety and prolong chain life. Problems, possible causes and instructions for solution are outlined in the following table.

Periodical inspection table

Problem	Possible cause	Solution
<p>Circumferential wear of plate</p> 	Wear	Replace the chain if wear loss becomes 5 percent of H.
<p>Oblique wear of plate and pin head</p> 	Misalignment of guide or pulleys	Align the unit.
<p>Stiff link</p> 	<p>Dust or foreign substances are contained in a bending portion</p> <p>Corrosion and rust</p> <p>Bent pin</p>	<p>Wash and lubricate.</p> <p>Replace the chain.</p> <p>Replace the chain.</p>
<p>Abnormal protrusion or rotation of pin head</p> 	Excessive tension by overload or insufficient lubrication	<p>Replace the chain</p> <p>Lubricate and eliminate overload.</p>
<p>Wear elongation</p> 	Wear	<p>Replace the chain when its length becomes 1.03L.</p> <p>Note: Wear elongation of a chain lowers its tensile strength.</p> <p>Wear elongation of 3% lowers the tensile strength by 18 percent.</p> <p>The wear life of chain can be improved by lubrication.</p> <p>Replace the chain.</p>
<p>Cracked plate (1)</p>  <p>Crack: From the hole of a link plate toward the end of the link plate in the direction perpendicular to tension direction.</p>	Load exceeding the allowable tension of chain	Replace the chain with a chain of higher maximum allowable tension, or lower the load or dynamic (shock) load.
<p>Cracked plate (2)</p>  <p>Crack: In an oblique direction against tension direction.</p>	Heavy rust or exposure to an acid or corrosive material	Replace the chain, and protect from corrosive circumstances.
<p>Broken plate (by high tension)</p> 	Overload	Replace the chain, and eliminate the cause of overload.
<p>Enlarged plate hole</p> 	Overload	Replace the chain, and eliminate the cause of overload.
<p>Corrosion of pit</p>	Corrosive circumstances	Replace the chain, and protect from corrosive circumstances.
<p>Wear of connecting pin</p>	Normal wear	Replace the worn component.