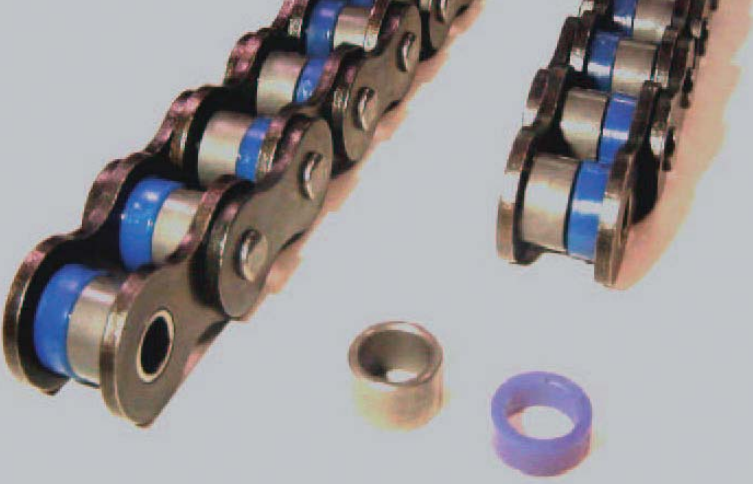

Unparalleled noise reduction

Super Low Noise Chain (UN) has achieved a higher drive performance while having equivalent noise reduction performance to Previous Low Noise Chain (TB). By improving the drive performance to the level of standard roller chains, Low Noise Chains are now applicable to many more machines and equipment.

Name	Super Low Noise Chain (UN)
	
Features	<ul style="list-style-type: none"> ① Approx. 10dB noise reduction compared to a standard chain ② Two Piece roller ③ Equivalent durability (strength) to standard roller chains
Functions	<div style="display: flex; align-items: center; justify-content: center;"> <div style="border: 1px solid black; padding: 5px; margin-right: 20px;"> Max. KW Rating 100% </div> <div style="border: 1px solid black; padding: 5px; margin-right: 20px;"> Noiseless 10dB </div> <div style="font-size: small;"> ※Noise reduction values differ by the chain sizes and conditions for use </div> </div>
Main uses	<div style="display: flex; justify-content: center; gap: 10px;"> <div style="border: 1px solid black; border-radius: 50%; padding: 5px; background-color: yellow;">PRINT</div> <div style="border: 1px solid black; border-radius: 50%; padding: 5px; background-color: yellow;">PACK</div> <div style="border: 1px solid black; border-radius: 50%; padding: 5px; background-color: yellow;">CONVEYOR</div> <div style="border: 1px solid black; border-radius: 50%; padding: 5px; background-color: yellow;">MACHINING</div> <div style="border: 1px solid black; border-radius: 50%; padding: 5px; background-color: yellow;">PARKING</div> </div>

■ Table of Low Noise Series

Chain No.	Super Low Noise
DID 40	UN
DID 50	UN
DID 60	UN
DID 80	UN

1. Drive performance equivalent to standard chains

Max. KW Rating
100%

Excerpt from the table of Drive Performance 40TB

No. of teeth of small sprocket	Small sprocket rpm			
	50	200	400	600
11	0.20	0.50	0.47	0.45
12	0.22	0.57	0.53	0.51
13	0.24	0.65	0.60	0.58
14	0.26	0.72	0.67	0.65

DID 40TB

DID 40TB VS DID 40UN
(Unit: kW)

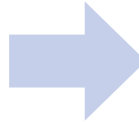

Excerpt from the table of Drive Performance 40 in the general catalog

No. of teeth of small sprocket	Small sprocket rpm			
	50	200	400	600
11	0.20	0.70	1.30	1.88
12	0.22	0.77	1.43	2.06
13	0.24	0.84	1.56	2.25
14	0.26	0.91	1.69	2.44

Super Low Noise DID 40UN

Set the chain speed within 210m/min.

Roller Chains for Power Transmission
Low Noise Chain Series

2. Noise reduction equivalent to Previous Low Noise chains

Noiseless
10dB

※Noise reduction value differs by the chain sizes and conditions for use

The noise emitted when the chain engages with the sprockets can be reduced by approx. 10dB. For conveyor chains, sliding noise of the rails and the rollers can be reduced as well.

3. Durability equivalent to standard chains

The chains exhibit durability higher than Previous Low Noise chains and at the same level as standard chains.

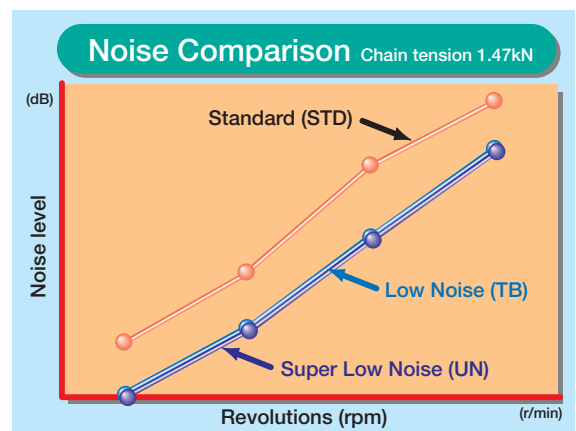

Structures of the chains and noise reduction mechanism

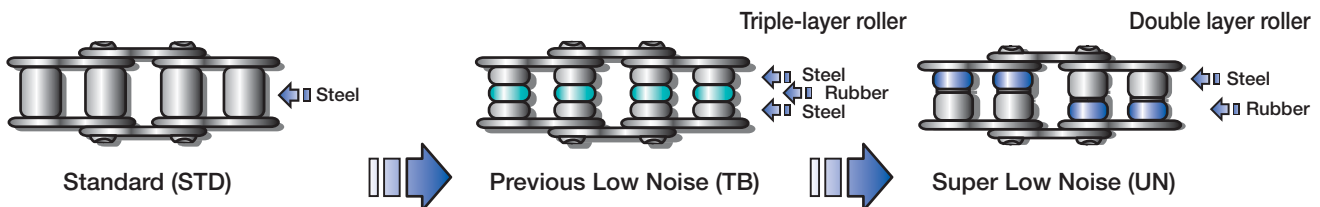

- Standard connecting links and sprockets can be used. Offset links are specialized.
- Low noise chains available in sizes DID40UN~80UN.
- Preventing partial wear of sprockets and rails

Compared to Previous Low Noise chains, the steel rollers of the Super Low Noise are in staggered assembling in the traveling direction to reduce partial wear of the sprockets and rails.

Super Low Noise Chain (UN)



A brand new low noise chain with unparalleled noise reduction

Super Low Noise Chain (UN) has achieved a higher drive performance while having reduced noise like Previous Low Noise Chain (TB). By improving the drive performance to the level of standard roller chains, Low Noise Chains are now applicable to many more machines and equipment.

Noise reduction comparison

There is about 10dB noise reduction to the noise from when the chain engages with the sprockets. (Fig. below) The sliding noise from the rails and the rollers can be reduced as well.

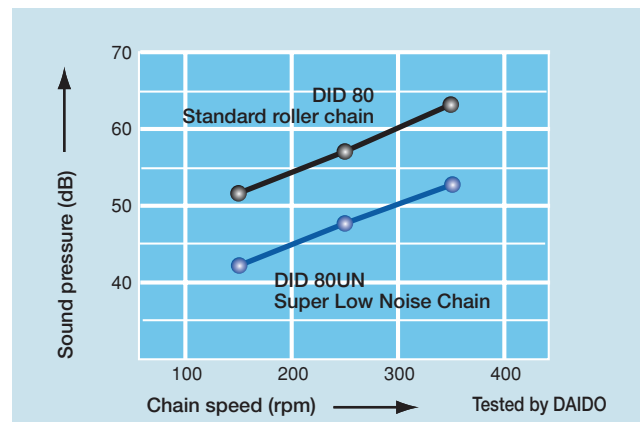

Features

- Super Low Noise Chain was developed in response to the needs for a wider application of low noise chains by modifying the triple-layer roller structure of the TB Chain into a double layer roller. Noise reduction level is equivalent to that of TB Chain.

Recommended uses

- Circumstances requiring the drive performance of chains at the noise level of belt conveyors
- Printing machines, packaging machines, office appliances etc

Allowable Load of Rollers

Unit: N(kgf)/piece

Chain No.	Allowable load
DID 40UN	78 (8)
DID 50UN	117 (12)
DID 60UN	196 (20)
DID 80UN	313 (32)

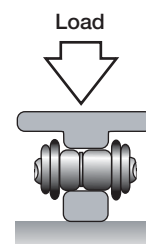

Selection of chains

See the "Selection by max. kilowatt ratings" (P120) or "Low-speed selection" (P121) for chain selection.

Note: Set the chain speed within 210 m/min.

Super low noise chains are available up to five strands.

Sprockets, connecting links and offset links

Standard sprockets and connecting links can be used. Offset links are also available.

It is recommended to use the sprockets with teeth of odd numbers or even numbers indivisible by four to engage them with the chain rollers.

Caution

The rollers are made of risen and their performance deteriorates when exposed to ultraviolet (UV) rays. In addition, do not use in circumstances where the resin roller are exposed to sprays and vapors of substances listed below:

Nonflammable hydraulic oil (phosphoric esters, water-glycol fluid), oils containing extreme-pressure additives, hot water, vapor, ester, ketone, organohalogen, pure aromatic compounds, strong acid, strong basic agents, strong acidic reagents, carbon disulfide, sulfur dioxide.

The applicable conditions are equivalent to those of standard roller chains.

The corrosion resistance against water, acid, alkaline, and other chemical substances are also equivalent to that of standard roller chains.

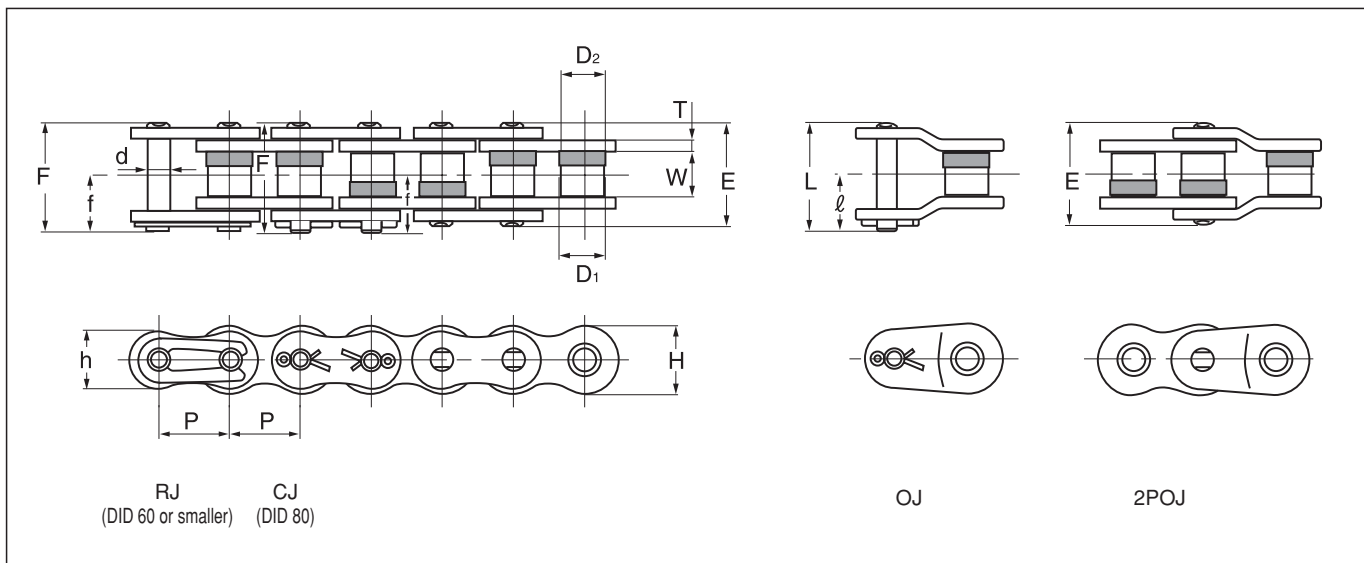

Dimensions

Unit (mm)

Chain No.	Pitch P	Roller link width W	Roller (Bush) dia.		Pin						Plate			Avg. tensile strength		Max. allowable load		Approx. weight (kg/m)
			D ₁	D ₂	d	E	F	f	L	ℓ	T	H	h	kN	kgf	kN	kgf	
DID 40UN	12.70	7.95	7.72	8.15	3.97	16.5	17.6	9.5	19.3	10.6	1.50	12.0	10.4	19.1	1,950	3.72	380	0.59
DID 50UN	15.875	9.53	9.85	10.40	5.09	20.3	21.9	11.6	23.1	12.1	2.00	15.0	13.0	30.8	3,150	6.86	700	0.98
DID 60UN	19.05	12.70	11.55	12.14	5.96	25.4	26.9	14.3	30.0	15.7	2.40	18.1	15.6	44.1	4,500	9.31	950	1.43
DID 80UN	25.40	15.88	15.34	16.10	7.94	32.8	35.3	19.0	37.1	19.5	3.20	24.0	20.8	78.1	8,000	14.7	1,500	2.36

Note: 1. The values of the average tensile strength and maximum allowable tension are for the chain body.

2. Consult us for multiplex chains and other specifications.

3. Refer to the table "Allowable Load of Rollers" on P96 for an optimum sprocket.