

Double Guard Chain (WG)



Steel chain approaching stainless steel chain in corrosion resistance

Double Guard Chain is highly corrosion resistant with coating of double layers of two different materials. Compared to the High-Guard Chain, it exhibits nearly doubled corrosion resistance in the salt water spray test, and can be used in mild alkaline and mild acidic conditions.

Features

- With its improved corrosion resistance, it can be used in circumstances where High-Guard or Rustless Chains cannot be used, and even in some conditions where only stainless steel can be used.
- The coating consists of environmentally friendly non-chrome material. To comply with the EU's Restriction of Hazardous Substances (RoHS) Directive, hexavalent chromium is not used.

Recommended uses

- Conditions that require both strength and corrosion resistance
Multilevel parking facility, moving decks, cleansing lines etc.
- Conditions exposed to rain or sea water
Machines installed outside, amusement machines
- Conditions exposed to mild alkaline and mild acidic chemical agents, sea water or wastewater. Various chemical plants and water treatment plants.

Surface conditions after corrosion test

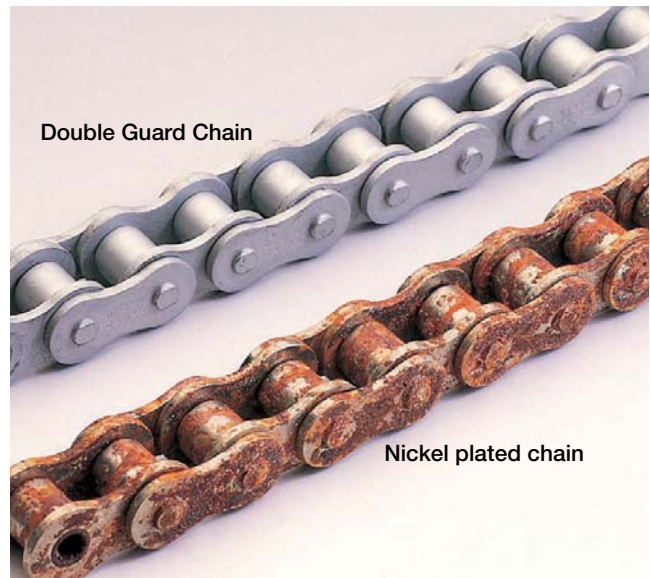

CASS test - Double Guard Chain: 60Hr, Nickel plated chain:

Performance Comparison Consult us about the selection of chains depending on your circumstances.

Name	Code	Strength Maximum allowance tension rate	Corrosive resistance			
			General atmosphere (Results of CASS test)	Conditions exposed to water or salt water	Alkaline resistance	Acidic resistance
Double-Guard	WG	100%	◎ (Double of High-Guard)	◎ (Double of High-Guard)	○	△ Resistant to mild acidity (up to PH3)
Hi-Guard	E	100%	○	○	△ (No alkaline resistance)	×
Standard	—	100%	△	× (Rusting)	△	× (Cracking)
Nickel plated	N	100%	○	△	○	△
Stainless steel	SS	10%	◎	◎	◎	◎

Note: ◎: Excellent, ○: Very good, △: Good, ×: No good



Selection of chains

Double Guard Chain has an equivalent strength to a standard roller chain. Please refer to p120~122 for chain selection.

Connecting links and offset links

R connecting links are used for high-guard chains #60 or smaller and C connecting links for #80 or larger, and OJ and 2POJ are used as offset links.

Sprockets

Standard sprockets for high-guard chains can be used since the dimensions are the same as standard roller chains.

Caution

- ① Use stainless steel chains if the chains will come in direct contact with food.
- ② Double Guard chain does not have a gloss like the nickel coated chain.
- ③ Unless not so specified by the customer, chains are coated with grease and shipped. If possible, oil the spaces between pins and bushes and bushes and rollers. Please use the recommended lubrication oil (P132) for the maintenance of the chain as oiling with grease can cause flexion failure.

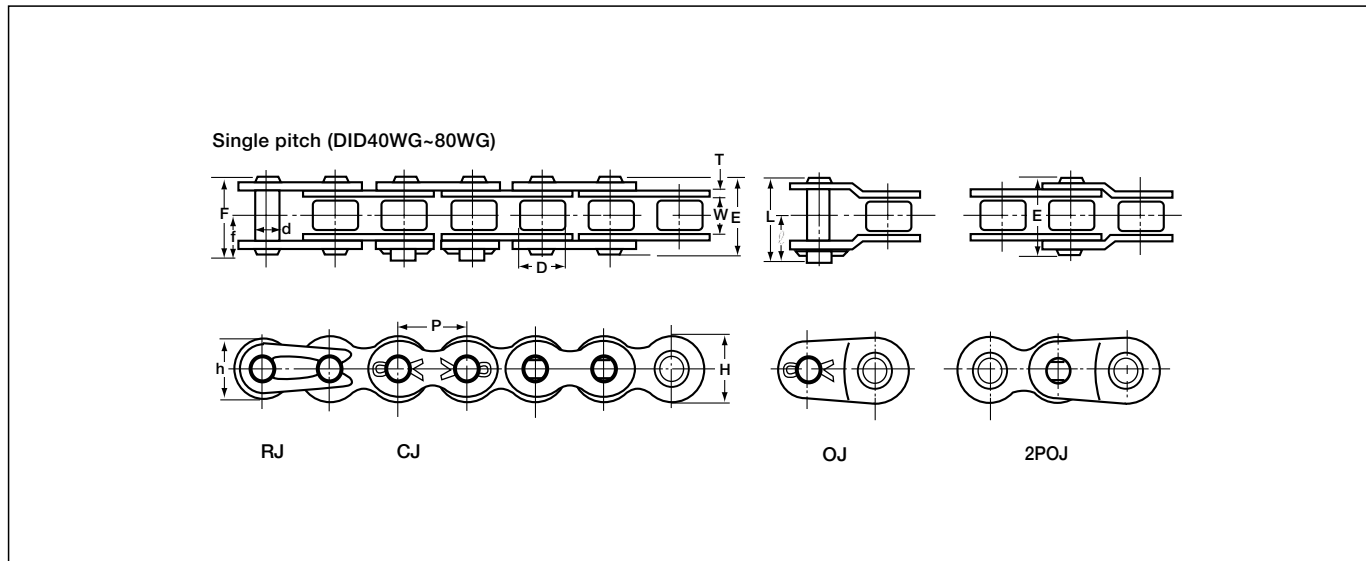

Dimensions

Unit (mm)

Chain No.	Pitch P	Roller link width W	Roller (Bush) dia. D	Pin						Plate			Avg. tensile strength		Max. allowable load		Approx. weight (kg/m)
				d	E	F	f	L	l	T	H	h	kN	kgf	kN	kgf	
DID 40WG	12.70	7.95	7.92	3.97	16.5	17.6	9.5	19.3	10.6	1.50	12.0	10.40	16.6	1,700	3.72	380	0.63
DID 50WG	15.875	9.53	10.16	5.09	20.3	21.9	11.6	23.1	12.1	2.00	15.0	13.00	28.4	2,900	6.86	700	1.06
DID 60WG	19.05	12.70	11.91	5.96	25.4	26.9	14.3	30.0	15.7	2.40	18.1	15.60	40.2	4,100	9.31	950	1.44
DID 80WG	25.40	15.88	15.88	7.94	32.6	35.4	19.0	37.1	19.5	3.20	24.0	20.80	75.0	7,650	14.70	1,500	2.55

Note: Ask us for the delivery time