

Seal Chain

By placing a seal ring between the inner and outer plates, this conveyor chain has grease enclosed between the pins and bushings. Chain endurance is significantly improved with this design as friction between the pins and the bushings is substantially lowered.

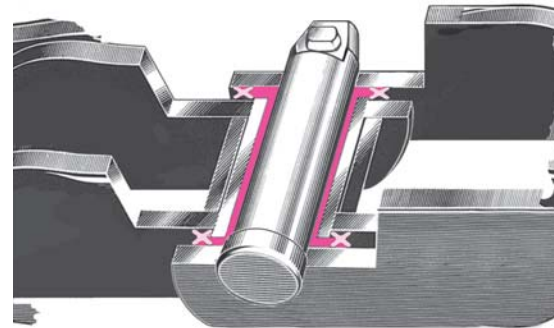

- Heat resistance of seal rings is approx. 80°C.
- Sprockets for Standard Conveyor Chains can be used.
- Various attachments are available upon request.

Application examples

- Equipment with tendency to elongate chains.
- Equipment used in severe circumstances.
- Maintenance-free is needed.
- Conveyor lines, construction machinery.

Comparison of Wear Resistance (no lubrication during testing)

- Comparison of Wear Resistance (no lubrication during testing)

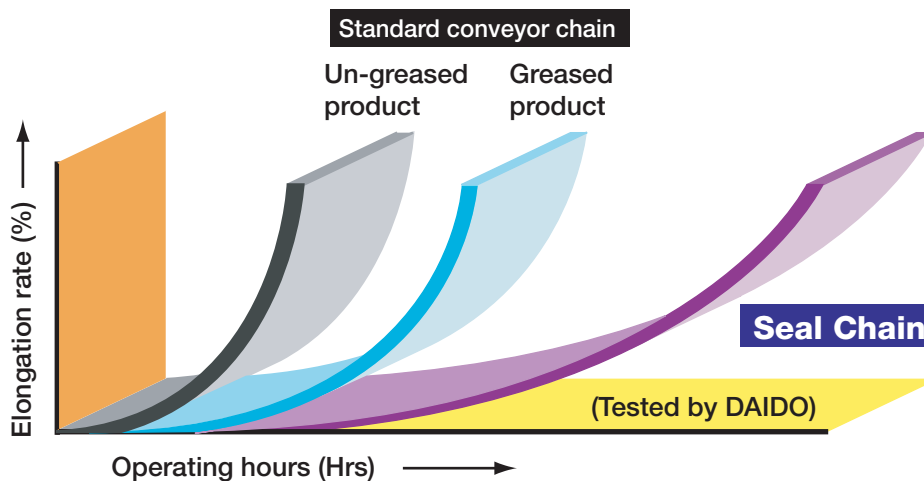

- By lubricating the Seal Chain from time to time, chain life can be further lengthened and the effects of rust resistance can be expected as well. Applicable lubrication oil: SAE30 to SAE40
Do not use gasoline, phosphate ester hydraulic fluids, and chemicals such as benzol, trichlene, and acetone, as they may damage the seal rings.

Dimensional Drawings: Seal Chains

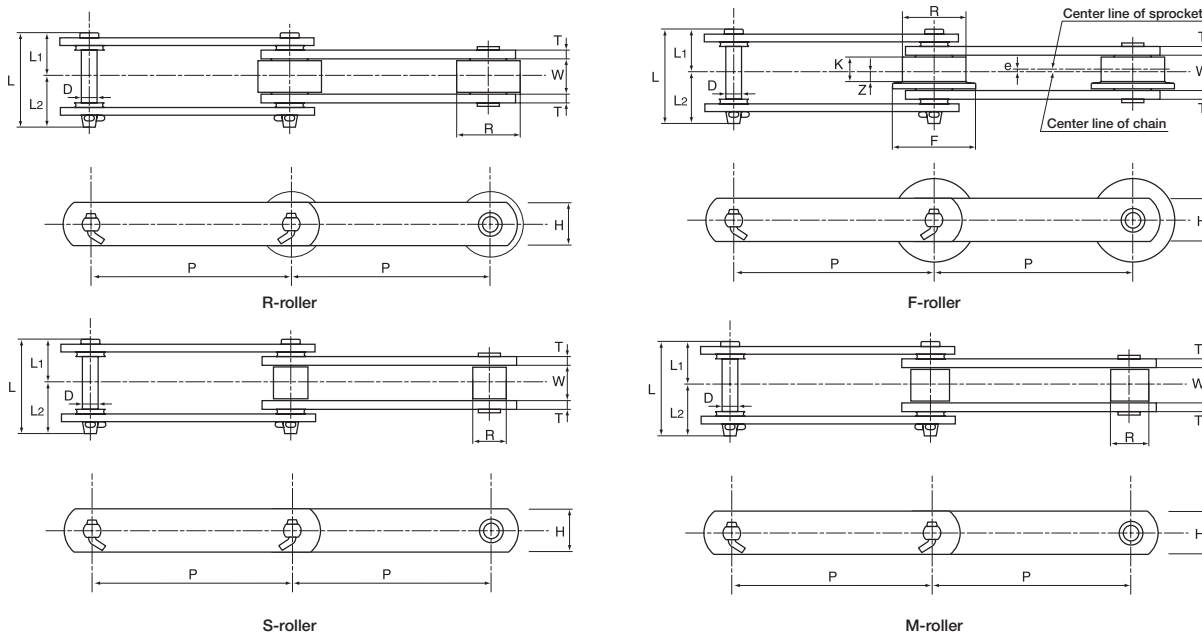

DK Conveyor Chains

Seal Chain

Chain No.		Avg. tensile strength kN (kgf)		Pitch	Width	R-roller		F-roller				S-roller M-roller		Pin				Plate		Approx. weight kg/m			
Chain size	Roller type	Normal A,J	Heavy duty K,E	P	W	R	R	F	K	e	Z	R	R	D	L	L1	L2	T	H	R-roller	F-roller	S-roller	M-roller
DK 19200V	R,F,S,M			200																11.6	12.2	8.5	8.7
DK 19250V	R,F,S,M	186 (19,000)	250 (25,500)	250	36.5	65	65	85	24	4	8	34.9	38.1	15.9	94.3	43.8	50.5	8	45	10.4	10.9	8.0	8.2
DK 19300V	R,F,S,M			300																9.6	10.1	7.6	7.9
DK 25200V	R,F,S,M			200																18.3	19.6	11.5	12.0
DK 25250V	R,F,S,M	245 (25,000)	353 (36,000)	250	51.8	80	80	105	35.5	5	12.5	40.1	44.5	19.1	117.9	54.9	63.0	9	50	16.0	17.1	10.7	11.1
DK 25300V	R,F,S,M			300																14.6	15.4	10.0	10.4
DK 19152V	R,F,S,M	186 (19,000)	250 (25,500)	152.4	36.5	57.2	57.2	75	24	4	8	34.9	38.1	15.9	94.3	43.8	50.5	8	45	11.9	12.3	9.2	9.5
DK 25152V	R,F,S,M	245 (25,000)	353 (36,000)	152.4	37.5	69.9	69.9	90	25	4	8.5	40.1	44.5	19.1	103.9	47.8	56.1	9	50	16.5	17.4	12.1	12.7

- Note: 1. The avg. tensile strength of a heavy duty chain is about 90% of that of the Standard Multipurpose Conveyor Chain.
 2. Sprockets for Standard Conveyor Chain can be used.
 3. The heat resistance of the seal rings is about 80°C.
 4. Consult us for sizes not mentioned above, heat resistance higher than 80°C, or other options like adding grease holes to pins.
 5. Ask us for delivery time.